



Piian Odor Control Systems

Mini Vaporizer System

Harnessing the Power of Nature to Solve Localized Odor Problems

The Piian Mini Vaporizer System combines nature's built-in odor-fighting capability with industrial-quality atomization technology. The result is a remarkable system that is effective in eliminating odors, completely safe and earth-friendly, easy to install and operate and that will provide years of low cost, trouble-free operation.

By using a built in air compressor and a vaporization tube, the Piian Mini Vaporizer System produces millions of 1 Micron sized droplets of ALL NATURAL Piian Odor Neutralizer. The vaporized odor neutralizer can be released into the air or conveyed to the odor source by a 1 1/2" (35mm) flexible hose.



The Finest Odor Control System on the Market

A rugged stainless steel cabinet encloses the pumping system and controls of the Mini Vaporizer System. The system includes a lower cabinet to lock up a 5 gallon (20 liter) pail of odor neutralizer; easy-to-use controls are safely located behind a Lexan cover. The unit can be conveniently mounted on a wall surface or on an optional pedestal.

Major Cost Saving Features

Annual Refill – by dispensing a super concentrated material in 1 micron sized droplets, the system only needs to be refilled once per year.

Advanced Digital Control Panel - insures ease of use, flexible operation and full automation.

Empty Alarm – the system shuts off and an alarm will sound when the odor neutralizer needs to be replaced.

Automatic Freeze Protection – when the temperature drops below 40°F (3°C), the system will shut down. For regions with extended cold weather conditions an optional heater is available that will activate on low temperature shut down to prevent freezing problems.

Advanced Monitoring – sophisticated digital features monitor the loads and condition of the system, easy to understand LED's alert the user to any problems.

Superior Construction – Stainless Steel and Lexan construction plus proven industrial quality components ensure reliability and durability even in the toughest operating environment.

One Year Warranty – the system comes with a full one year warranty. (Full warranty details available by request)

Lifetime Warranty Option – provided you choose to only use Piian Odor Neutralizer in the Mini Vaporizer System we will honor a lifetime warranty on the system. (Full lifetime warranty details available by request)



Reasons why Mini Vaporizer Systems are the Best Solution to Small Scale Odor Problems

- Performance** – The Mini Vaporizer produces an extremely efficient vapor or 1 micron sized odor neutralizing droplets, additionally Piian Odor Neutralizer has been independently tested and proved effective in laboratory tests.
- Safety** - Made from all natural oils and plant extracts, Piian Odor Neutralizer is proven safe.
- Price** - Compared to similar systems, Piian Mini Systems are the least expensive to own and operate.
- Reliability** – Piian Mini Systems are engineered to withstand the rigors of the waste environment.

APPLICATIONS:

- Garbage Compactors
- Trash Rooms / Trash Areas
- Multi Storey Garbage Chutes
- Air Handling Systems / Building Ventilation Systems
- Large Public Restrooms (Stadiums etc)
- Sewage Tanks, Wells, Headworks & Beltpress Rooms
- Industrial Wastewater Processing Tanks and Equipment
- Grease Traps / Grease Processing Rooms
- Industrial Processing Equipment

MARKETS:

- Shopping Malls
- Multistory Office / Apartment Buildings
- Hospitals
- Schools
- Grocery Stores
- Airports
- Hotels
- Food Service
- Sewage & Industrial Wastewater Treatment

Harnessing Nature to Solve Odor Problems.

Piian Mini Vaporizer Systems use Piian Odor Neutralizer, a completely natural proprietary blend of plant extracts, essential oils and emulsifiers. When sprayed, atomized or vaporized, molecules of this natural solution surround odorous gases causing immediate odor neutralization, followed by complete destruction of the gas through a biodegrading action. This is an entirely natural process, completely safe and environmentally benign.

Independent laboratory tests, field tests and a long track record have proven Piian Odor Neutralizers ability to destroy common odorous gases and compounds such as Hydrogen Sulfide, Ammonia, Sulfur Dioxide, Mercaptans, Carbon Disulfide, Acetic Acid / Anhydride, Phenols and Styrene.

Additional laboratory tests have verified that Piian Odor Neutralizer is completely safe for dispersion in a workspace environment, manufactured completely from food grade and pharmaceutical grade ingredients; it is non-toxic, non-sensitizing, non-flammable, non-reactive, non-volatile, bio-degradable and ecologically safe.

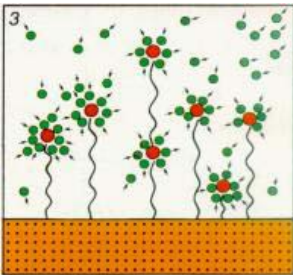

Manufactured by Piian Systems, Palm Springs, CA 92264, U.S.A.

Tel: (760) 778-4370 Fax: (760) 778-4368

Email: info@piian.com Web: www.piian.com

Pricing Subject To Change without Notice

Page 1

Distributed By:

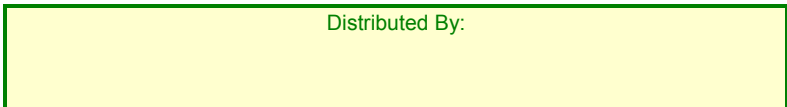

Piian Odor Control Systems

Mini Vaporizer System

The Mini Atomizer System consists of a 1/3 HP (0.5 kW) compressed air module enclosed in a vandal resistant 304L 20 Gauge stainless steel chassis and cabinet to lock up a 5 gallon (20 Liter) pail of odor neutralizer, a built in stainless steel 0.04GPH (150 cc per hour) x 1 1/2" (35 mm) permeation tube creates 1 micron sized vapor of odor neutralizer droplets.

The compressor unit is secured to a wall close by the treatment area and vaporizes super fine 1 micron sized odor neutralizer droplets into the surrounding environment or the vaporized odor neutralizer may be conveyed to the odor treatment point by a 1 1/2" (35mm) diameter flexible hose.

The vaporization process is ultra efficient meaning only very small quantity of odor neutralizer is required for effective odor control. There is absolutely no wetting, dripping or other moisture problems caused by the Mini Vaporizer System as it converts 100% of the odor neutralizer it consumes to an aerosol.

Easy-to-use controls are located in a NEMA 4X enclosure behind a Lexan cover that can be locked if required. The cycling operation of the unit is set using two simple knobs, the first knob controls how long the unit remains off and the second knob controls how long the unit sprays. Indicator lights show when the unit has power, another light shows when the unit is in operation and a buzzer and separate light alerts the user if the unit has run empty of odor neutralizer. Controls are manufactured and assembled to meet NEC and IEC Standards. Standard power supply is 115 vAC / 60Hz, 230 vAC / 50Hz is available.

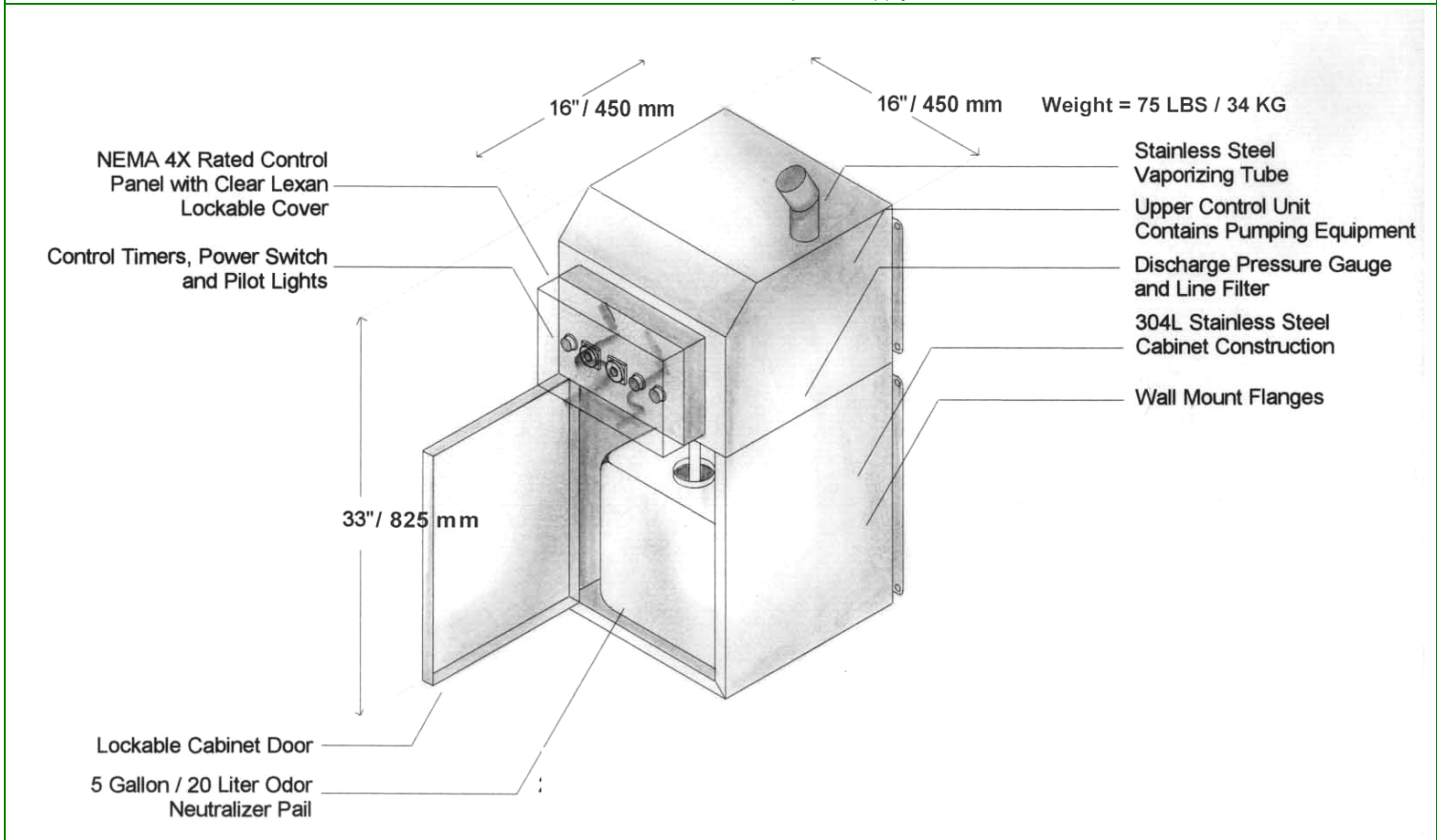

Mini Vaporizer System Items	Part #	Description	Price
Standard Model – 115vAC	MMPU0001	Includes 115 vAC – 60Hz compressed air module, stainless steel chassis, Nema 4 control panel with clear lockable cover, pilot lights for power, operation and fault, EZ repeat cycle function, tank empty alarm, interlock option, 1 Micron x 0.04 GPH built in vaporizing tube and empty 5 gallon pail.	\$1295.00
Standard Model – 115vAC	MMPU0002	Includes 230 vAC – 50/60Hz compressed air module, stainless steel chassis, Nema 4 control panel with clear lockable cover, pilot lights for power, operation and fault, EZ repeat cycle function, tank empty alarm, interlock option, 1 Micron x 0.04 GPH built in vaporizing tube and empty 5 gallon pail.	\$1295.00
230/460 vAC 50/60Hz 3 Phase Power	MMTF0001	For 230/460 vAC 3 phase power supply systems in the USA and most other countries.	\$150.00
Mounting Pedestal	MMFP0001	Stand Alone Pedestal for Mini Units	\$185.00
Piian Odor Neutralizer Commercial Concentrate – 1 ea x 5 Gallon Pail	PNCC0105	A 5 Gallon pail of concentrate is dispensed from a Piian Mini Vaporizer without any dilution. The 5 Gallon pail of ready to use solution fits into the Mini lower cabinet.	\$339.00
Complete Starter Kit	MMSK0007	Includes: 1 ea - Mini Vaporizer System (115 vAC 60 Hz) 1 ea – 5 Gallon Pail of Piian Odor Neutralizer	\$1634.00
Complete Starter Kit	MMSK0008	Includes: 1 ea - Mini Vaporizer System (230 vAC 50/60 Hz) 1 ea – 5 Gallon Pail of Piian Odor Neutralizer	\$1634.00